

# Buttonhole and Edge Sewing Machine Technology Training To Increase the Quality Production of Small Convection Creative Industry in Probolinggo

*by Riza Bahtiar Sulistyan*

---

**Submission date:** 25-Aug-2022 11:18AM (UTC+0900)

**Submission ID:** 1886681796

**File name:** Paper\_PKM\_Iskandar\_Jurnal\_2.docx (1.49M)

**Word count:** 3630

**Character count:** 19142

# Buttonhole and Edge Sewing Machine Technology Training To Increase the Quality Production of Small Convection Creative Industry in Probolinggo

Ahmad Iskandar Rahmansyah<sup>1</sup>, Alief Muhammad<sup>2\*</sup>, Joni Hendra<sup>3</sup>, Abdul Basit<sup>4</sup>, Siti Masluha<sup>5</sup>, dan Dani Hari Tuggal Prasetyo<sup>6</sup>

1,3,5 Faculty of Economic, Universitas Panca Marga, Probolinggo, Indonesia

2,6 Faculty of Engineering, Universitas Panca Marga, Probolinggo, Indonesia

4 Faculty of Teaching and Education, Universitas Panca Marga, Probolinggo, Indonesia

\*Corresponding Email: [aliefmuhammad@upm.ac.id](mailto:aliefmuhammad@upm.ac.id)

## Abstract

Based on the culture of new clothes on the New Year, Eid, and other special days, the demand for convection products will increase drastically. This condition is a big obstacle for small businesses in the creative industry in Indonesia, especially in Probolinggo. Increasing the amount of convection production in Probolinggo is by applying new technologies to accelerate the production. If convection production, both custom and general order, can be made quickly, the amount of production will increase. A buttonhole sewing machine is a machine that has the ability to embroider and buttonhole automatically. Edge sewing machine, a machine that works as a tool that is able to sew and smooth the edges of the fabric automatically. With these two machines, convection products will be faster. Both machine training service activities were carried out well. The results made using a buttonhole sewing machine show a good and short level of neatness. Edge sewing machines also provide satisfactory results. To sew and tidy up the fabric, it can be done quickly and neatly. All forms of service activities are carried out to be able to solve the problems experienced by small business partners in the creative convection industry in Probolinggo.

**Keyword:** Training, Sewing Machine, Small Industry

## INTRODUCTION

The creative industry is one of the fastest-growing industries in Indonesia. This industry has experienced very high growth in the last few decades. As reported by the Study of the Indonesian Creative Industries, in the 2013-2018 period, the average contribution of the Gross Domestic Product (GDP) of the Indonesian Creative Industries reached 7.38 percent of the total national GDP (Adwiyah et al., 2020). The export value of creative industries contributed 9.71 percent to the full value of national exports with jobs reaching 5.4 million workers (Mursalina & Masrur, n.d.).

Many cities in Indonesia have significantly contributed to the growth of the creative industry in Indonesia, especially in the convection industry. Based on the results of the SE2018 world economy list, the convection business occupies 5 of 28 processing industry products with high potential and high (Handayani, 2020). So considering the facts of the convection industry, the current convection business is becoming very complex. This condition is then followed by another fact that consumers today are becoming more selective in choosing products (Hamid, 2015). In addition, consumer demand based on the culture of new clothes on the New Year, Eid, and the commemoration of certain days adds to the demand for products which is increasing drastically (Yaqin et al., 2021). This condition is a big obstacle for MSMEs in the creative convention industry in Indonesia, especially in Probolinggo, which still has limited numbers and production speeds. In addition, the brand image is so little and the supply chain management capability in Probolinggo is still very low.

The efforts to increase the amount of convection production in Probolinggo are by applying new technologies to accelerate the manufacture of convection products. If convection production, both custom and general, can be made quickly, the amount of production will increase (Lucky, 2020). So that the profits will be more and the needs of consumers will be met. Especially in custom/ordered convection products, the speed of receiving and working on orders is very important (Haslindah & Rusyaid, 2020). The technology to be able to accelerate the manufacture of convection products is to use of a buttonhole sewing machine and an edge sewing machine.

A buttonhole sewing machine is a sewing machine that has the ability to embroider and cut buttonholes automatically (Komárek et al., 2012). In addition, the size of the hole is also given a limit that can be adjusted on the machine so that each hole has the same limit and size. For example, on shirts, suits, pants, and others that use button accessories. Next is the edge sewing machine, the edge sewing machine functions as a tool that is able to sew and smooth the edges of the fabric automatically (Beran et al., 2016). This machine also provides a cutter that will be sewn neatly at the same time. So to work on clothes, skirts, veils and so on will be faster.

## METHOD

The current trend of sewing machine development is to shorten the time in the sewing process and increase its productivity (Priandew, 2020). Other demands for sewing machines produced today are for example the ability to run quietly, with minimum vibration, long service life, and easy operation of heavy equipment (Rodhiyah, 2015). Sewing machines generally use a floating needle system, to be able to produce various types of "real hand stitches" as shown in figure 1.

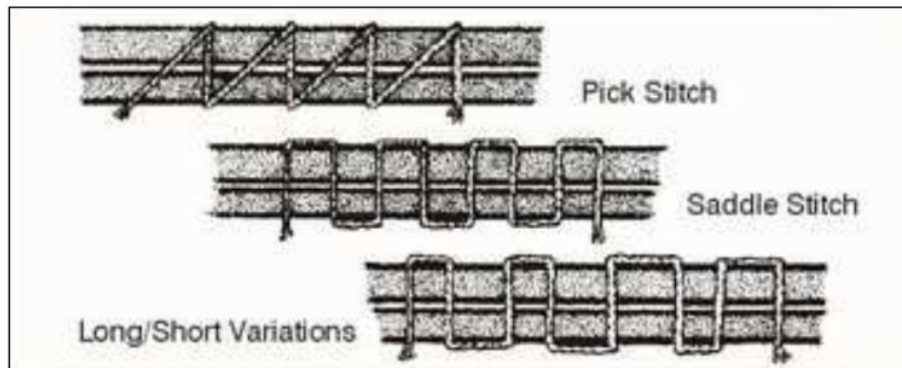

Figure 1. Sewing pattern of sewing machine

The machine uses a double-pointed needle that has an eye in the middle, as shown in figure 2. Using two-needle rods, one above and one below the work plate (Komárek et al., 2012). Furthermore, lengths of thread are passed through the material at each stitch, reproducing the tailor's work, accurately and at a speed unmatched by a human hand. The needle rod is shown in figure 3.



Figure 2. Double-pointed needle shape

The needle rod performs a backward movement to form a square obtained through the cam mechanism. Currently, home-scale sewing machines operate up to 190 rpm. However, in the convection industry, manufacturers can operate at 250 rpm. This speed can be achieved without changes to the engine design. However, in such high settings, the sewing machine can cause considerable vibration and high levels of noise intensity which are certainly undesirable (Beran et al., 2016). Then, due to the limitations of hygienic regulations for cottage industries, such high vibrations and noise are not legally acceptable. At a speed of 250 rpm, engine components also wear out faster, with the consequence of shorter engine life.

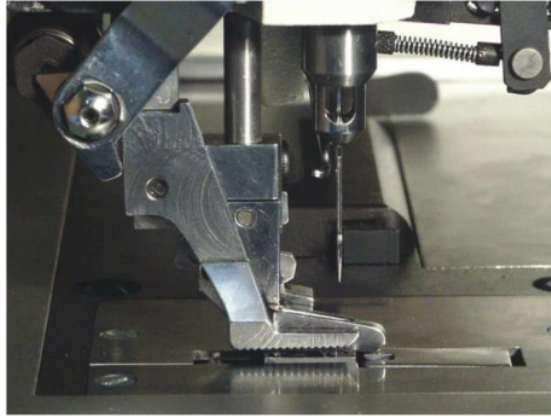

**Figure 3. Needle rod shape**

The well-known automatic button sewing machines are generally equipped with a work table and a spare cloth plate that is placed movably on the table (Komárek et al., 2012). Fabrics such as coat sleeves are placed on top of the fabric reserve plate. This machine is also equipped with a button holder that can be moved vertically about the fabric reserve plate. The attached pictures show an embodiment of this button sewing machine. Fig. 4 shows the workbench, fabric spare plate, and button holder.

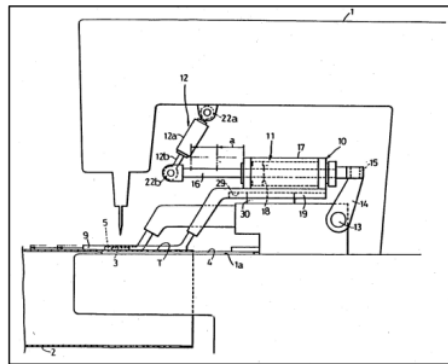

**Figure 4. Design drawing of a button sewing machine (side view)**

Now, suppose the machine is used to sew decorative buttons on the sleeves of a coat. The sleeve is suspended on a workbench supported by a spare plate as shown in Fig. 5, and the button holder is operated to sew the buttons in the desired position on the sleeve where the button holder and the spare plate are moved simultaneously to place the buttons in the desired position (Beran et al., 2016).

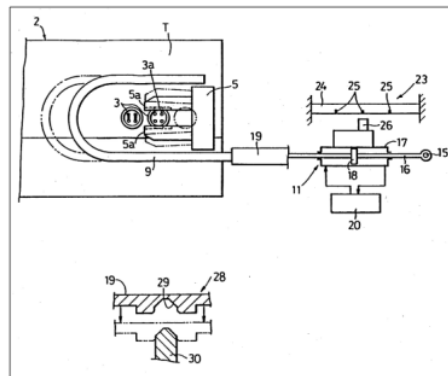
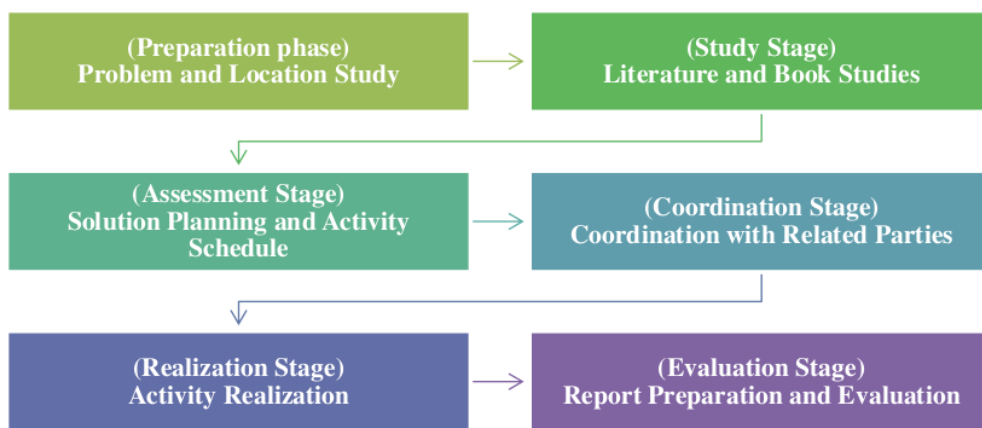

**Figure 5. Design a button sewing machine drawing (top view)**

Known automatic button sewing machines of the type are adapted to sew buttons on sleeves one at a time. However, if two or more studs are to be installed in a series, manual work must be done in shifting the sleeve portion from button to latch. The need to manually shift the sleeve negates the performance advantage of automatic button sewing. Another disadvantage is the difficulty of visually placing the button in the desired position (Beran et al., 2016).

This machine is geared toward solving the problems shown concerning sewing machines and has the aim of providing an automatic buttonhole sewing machine that can make a precise number of buttons in a sequence (Komárek et al., 2012). Another purpose of this machine is to provide automatic buttonholes for sewing machines that allow inexperienced operators to sew buttons on garments easily. The further purpose of this machine is to provide an automatic buttonhole sewing machine that sews buttons on clothes quickly.

This service activity will be organized into 6 stages. The first stage is the preparation stage. At this stage, the aim is to find the problems that occur. In addition, information about partners is also dug deeper, including the place and location. At this stage, it has an initial role to find the subject and object of this entire service activity. The convection industry which is the subject of this activity is located in Bengkingan Hamlet, RT 03 RW 01, Kalirejo Village, Dringu District, Probolinggo Regency.



**Figure 6. Diagram of the stages of community service**

The second stage is the stage of the study carried out to solve the problems that have been found. At this stage, a solution must have been found for all activities to be carried out. Literature and literature review is needed so that the solution can solve the problem. In addition, the solution planning process has a solid foundation.

The third stage is the assessment stage, where at this stage it is necessary to have clear information about partners and problems that have occurred and the basis for solving the problems. The purpose of this stage is to plan in detail the design of the realization of activities for the solution. In addition, several plans for determining the schedule have also been planned at this stage which will later become material for discussion and coordination with partners and related parties.

The coordination stage is the stage where various kinds of discussions and coordination are carried out on activities to be carried out by partners and together with related parties such as the Head of the local RT and RW. Activities will be explained to the parties in detail and detail so that there are no misunderstandings between the various parties. Then, the design of the activity schedule will also be discussed to get the right time for the activities to take place.

The realization stage of the activity is a day where service activities take place that provides training on the two machines, namely the button sewing machine and the Edge sewing machine. All activity designs will be carried out at this stage to be a solution to the problems that were found in the early stages. So, it is hoped that at this stage it can provide benefits in solving problems and being able to increase convection production in Probolinggo.

The final stage is the evaluation stage which contains the preparation of activity reports and evaluation of the results of activities that have been carried out. At this stage, observations and assessments of activities are

carried out on the achievement of the expected results. So, there is a sustainability process that occurs or the impact resulting from these service activities.

## **RESULTS AND DISCUSSION**

In the Probolinggo Regency area, there are several SMEs engaged in the home industry business, one of which is the convection industry located in Bengkingan Hamlet, RT 03 RW 01, Kalirejo Village, Dringu District, Probolinggo Regency. In a day, Leni's convection industry spends an average of 8 m to 12 m of fabric to meet market demand in Probolinggo and its surroundings. The raw materials come from a textile shop in the Probolinggo city area which has been working with production partners for a long time. Clothing production is tailored to the latest trend designs and especially consumer demand. Based on information obtained by production partners, in a day the clothes produced reach 4 to 7 clothes. Even when demand soars, such as on Eid al-Fitr and the new school year, production can be more than that amount.

The convection industry, which is managed by Leni, has 4 employees. The employee is a graduate who ends up being a housewife. With the convection SMEs owned by Leni, it is enough to empower the surrounding community. Textile raw materials come from stores that have worked with partners for a long time, so if the textile raw materials that consumers want are not in the store, the production partners look for raw materials in the Pasuruan area. Regarding consumer demand, Leni said serving orders based on the availability of raw materials and a queuing system, considering a large number of consumer requests and the complexity of the desired design. Their orders will explode ahead of Eid al-Fitr.

Production partners usually handle consumers in the Probolinggo area and its surroundings, but several times partners also handle consumers from the city of Malang. Production partners do not yet have a marketplace or online shopping application because currently they still rely on the Whatsapp application to handle consumers and as a marketing medium. One piece of clothing is sold for Rp. 75 thousand to 150 thousand, but the price given depends on the quality of the raw materials and the level of complexity of the design requested by the consumer.

In general, the stages of the clothing manufacturing process are as follows, as shown in Figure 7:

1. Measurement of the consumer's body by visiting the place where the consumer is located or the consumer comes to the place where the production partner is located. The purpose of this measurement is to avoid errors in clothing sizes. In addition to this, if you get a lot of orders, the measurement system is carried out in groups.
2. Clothing design, clothing design is carried out according to the wishes of consumers by sending their clothing designs via WhatsApp messages. In addition to being tailored to the design desired by consumers, sometimes some consumers fully entrust the design to the production partner or entrust a slight change from the desired design to match the consumer's body.
3. Purchase of raw materials is carried out after designing so that the raw materials to be purchased are by the design of the clothes and match the demands of consumers. The partners purchased raw materials at a textile shop in the Probolinggo city area, which has been working with production partners for a long time. In purchasing raw materials, of course, there are several considerations, namely the quality of the material, the price of the material, the pattern or color of the material, estimating the length of the fabric purchased according to the size so that unwanted excess raw materials do not occur, and choosing such as threads, buttons, hard fabrics, and some other knick-knacks to support the needs of making these clothes.
4. Patterning of clothes that are shaped according to the consumer's body measurements that have been measured before. Patterns are pieces of paper in the form of prototypes of clothing parts so that there are no mistakes in cutting raw materials.
5. Sewing process or production process. In this process, the production partner will sew by separating the parts of the garment such as the body, sleeves, and collar and then combining them into clothes.
6. Finishing, in this process, the buttons are punched, the installation of buttons on clothes and other knick-knacks to beautify the clothes according to the desired design, the fireplace at the edges of the clothes or veil, the process of cutting or cleaning leftover sewing threads, as well as the process of attaching labels.
7. Packaging, in this process the production partners use plastic packaging for clothing.
8. Products are ready to be delivered or picked up by consumers.

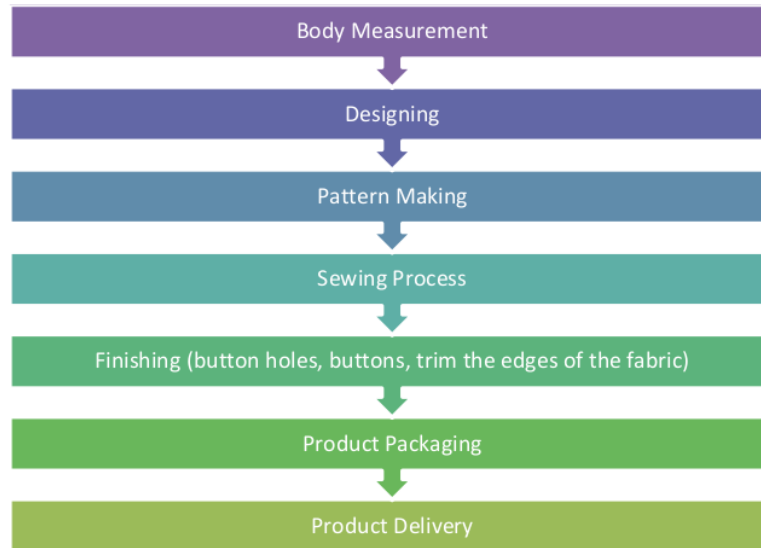

**Figure 7. Production Partner Production Process Diagram**

There are several obstacles experienced by production partners, namely in the buttonhole and edge sewing processes. Where the production partners in the process of making buttonholes still use the conventional method, namely using a single sewing machine. The machine used is also often re-adjusted in terms of buttonhole size or returned to a single sewing machine, making it prone to damage. In addition to this, production partners also experienced problems with the process of firing the edges of the clothes and veils, which was done manually or by using a seam technique, namely using a single sewing machine. By doing it manually, of course, the production of clothes is quite time-consuming and the expected results are sometimes not neat.



**Figure 8. Manual buttonhole process with the production partner's single machine**

With these constraints, the production process is very inefficient, which is about 7 minutes for buttonholes and about 15 minutes for tidying the edges of clothes in 1 garment. With these constraints, of course, the production process is hampered, where the time required for production is usually 5 days to 8 days for an order of 10 clothes or if you get an order that exceeds 30 clothes, usually 2 weeks to 1 month. For more details, it can be seen in Figure 8, where the production partner is doing buttonholes using a manual buttonhole machine as a stage of the clothing production process. After knowing these conditions and constraints, production partners need technological improvements by applying buttonhole machine technology and edge sewing machine technology, to help overcome the constraints of production partners.



**Figure 9 Documentation of button sewing machine and sewing machine training documentation**

Training activities are carried out as an effort to provide solutions to the problems and constraints presented by partners. The activity was carried out on August 6, 2022, at 7.30-15.30 WIB as shown in Figure 9. The training activities were delivered in the form of theoretical and practical material to be able to operate the button sewing machine and the edge sewing machine. The activity went very well seeing the enthusiasm of partners and other employees.



**Figure 10. Buttonhole Sewing Machine**

The results made using a button sewing machine in Figure 10 show a good level of neatness in a short time. According to partners, the process takes a long time around 30-60 minutes. However, if you use a button sewing machine, it can be done in less than 15 minutes regardless of the measurement time. Partners are also happy with the results made by the machine in Figure 11 and believe that this technology can speed up the production process of shirts, shirts, pants, and others that have buttons.



**Figure 11. The results of the work using a button sewing machine**



Not only button sewing machines, but edge sewing machines also give satisfactory results as shown in figure 12. To sew and trim pieces of cloth, it can be done very quickly and neatly as shown in picture 13. This machine is suitable for applying to veils, pants, skirts, and others that have wide cuts. The former wide pieces can be trimmed very quickly and neatly. Of course, if it is done with an old sewing machine and by hand, it will take a very long time.



**Figure 12. Edge Swing Machine**

All activities are carried out to be able to resolve the obstacles and problems experienced by the convection creative industry MSME partners. It is acknowledged by partners that a few days after the training, the processing of orders can be done faster and easier. In addition, the ease of use of this tool accelerates adjustments by partner employees in using it.



**Figure 13. The results of the work using an edge sewing machine**

## **CONCLUSION**

The buttonhole sewing machine and edge sewing machine training service activities can be carried out very well and smoothly. The results made using a buttonhole sewing machine show a good level of neatness in a short time. Not only buttonhole sewing machines, but edge sewing machines also provide satisfactory results. Sewing and tidying up pieces of fabric, it can be done very quickly and neatly. All forms of service activities are carried out to be able to resolve the obstacles and problems experienced by the MSME partners of the creative convection industry in Probolingo. It is acknowledged by partners that a few days after the training, the processing of orders can be done faster and easier. In addition, the ease of use of this tool accelerates adjustments by partner employees in using it.

## **REFERENCES**

- Adwiyah, R., Cintyawati, C., Firmansyah, F., Mustikawati, F., Fatimah, S., & Islami, V. (2020). Boosting the Performance of Convection Creative Industry Through Supply Chain Management and Brand Image Enhancement. 409(SoRes 2019), 608–612. <https://doi.org/10.2991/assehr.k.200225.132>
- Beran, J., Bílek, M., Komárek, J., & Němeček, P. (2016). Experimental analysis of the sewing machine. MATEC Web of Conferences, 89, 1–5. <https://doi.org/10.1051/mateconf/20178901002>
- Hamid, A. (2015). Pemberdayaan Ekonomi Perempuan melalui Usaha Mikro Konveksi. Raheema, 3(2), 173–184. <https://doi.org/10.24260/raheema.v3i2.570>
- Handayani, M. (2020). Strategi Home Industri Konveksi Dalam Meningkatkan Pendapatan Rumah Tangga Masyarakat Kota Binjai (Studi Kasus Abu Bakar Konveksi Mencirim Binjai Timur). Jurnal Ilmu Manajemen Dan Kewirausahaan, 1(Desember), 1–108.
- Haslindah, H., & Rusyaid, H. I. (2020). Strategi Pengembangan Pasar Pada Usaha Konveksi Dan Sablon Dalam Perspektif Ekonomi Islam. Islamic Economic and Business Journal; Vol 2, No 1 (2020). <https://www.jurnal.iain-bone.ac.id/index.php/ieb/article/view/2994>
- Komárek, J., Beran, J., Lima, M., Machado, J., & Silva, J. (2012). Finding the Optimal Setting of the Sewing Needle Transfer Mechanism Using Simulation Software. 41st Textile Research Symposium, 1–4.
- Lucky, S. (2020). Analisis Swot Pengembangan Industri Konveksi Perusahaan Kogaya Dalam Menghadapi Barang Import Dari China. Jurnal Ekonomi Manajemen Sistem Informasi, 1(6), 532–542. <https://doi.org/10.31933/jemsi.v1i6.167>
- Mursalina, R., & Masrur, M. (n.d.). Pengaruh Adanya Home Industri Konveksi dalam Meningkatkan Kesejahteraan Masyarakat dalam Perspektif Ekonomi Islam. 1, 157–163.
- Priandew, N. M. M. (2020). Berbagi Pengetahuan: Kinerja Bisnis Dan Inovasi Ukm Bordir Dan Konveksi Di Kabupaten Kudus. Jurnal Bingkai Ekonomi, 5(2), 16–26.
- Rodhiyah. (2015). Dampak Sosial Ekonomi Keberadaan Usaha Kecil Menengah (UKM) Konveksi di Kota Semarang. Jurnal Ilmu Sosial, 14(1), 1–14. <https://doi.org/https://Doi.org/10.14710/JIS.14.1.2015.1-14>
- Yaqin, A., Lutfillah, L., & Muhtadin, R. (2021). Strategi Membangun Ekonomi Pesantren melalui Sentralisasi Kebutuhan Fashion Pada Industri Konveksi Pondok Pesantren Nurul Jadid. Ekonomica Sharia: Jurnal ..., 7(1), 1–16. <https://ejournal.stebisigm.ac.id/index.php/esha/article/view/298>

# Buttonhole and Edge Sewing Machine Technology Training To Increase the Quality Production of Small Convection Creative Industry in Probolinggo

## ORIGINALITY REPORT

4%

SIMILARITY INDEX

3%

INTERNET SOURCES

4%

PUBLICATIONS

0%

STUDENT PAPERS

## PRIMARY SOURCES

1

[dspace.tul.cz](https://dspace.tul.cz)

Internet Source

2%

2

Jaroslav Beran, Martin Bílek, Jiří Komárek, Pavel Němeček. "Experimental analysis of the sewing machine", MATEC Web of Conferences, 2016

Publication

<1%

3

Submitted to University of Ulster

Student Paper

<1%

4

F A Hidajat, B I Hidajat. "Design of assessment based on guided discovery to improve the quality of teachers' professionalism of mathematics", Journal of Physics: Conference Series, 2020

Publication

<1%

5

Dedi Joko Hermawan. "PERAN DESAIN LAYOUT DAN PEMELIHARAAN FASILITAS PRODUKSI DALAM MENUNJANG KELANCARAN PROSES PRODUKSI PADA RAJA

<1%

# MIE COKRO KOTA PROBOLINGGO", Capital: Jurnal Ekonomi dan Manajemen, 2018

Publication

---

---

Exclude quotes      Off

Exclude matches      Off

Exclude bibliography      On